

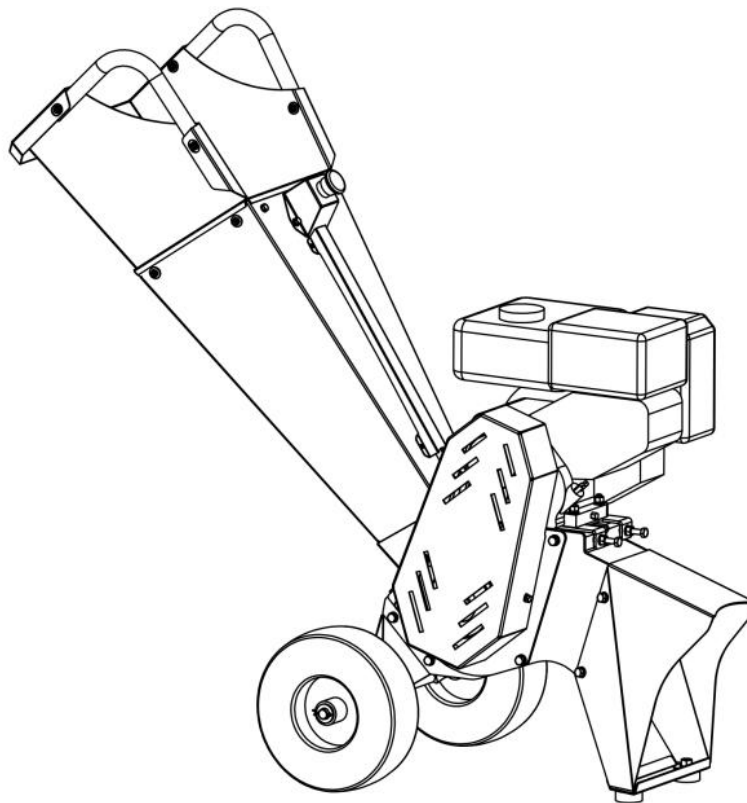

---

# Chipper Shredder User's Manual



## **JONCO SERIES**

**ARTICLE# R08PL R12PL    Model# CP20/CP30**

**Please read through this owner's manual carefully before using the product, to ensure the safety of yourself and others.**

\*Due to continuing improvements, actual product may differ slightly from the product described herein.



# Index

<b>1. INTRODUCTION</b> .....	1
<b>2. SAFETY AND SECURITY MEASURES</b> .....	1
2.1. USERS .....	2
2.2. PERSONAL PROTECTION .....	3
2.3. ENVIRONMENT SECURITY .....	4
2.4. SAFETY IN THE WORK AREA .....	4
2.5. SAFETY IN THE USE OF FUELS .....	5
2.6. CARE AND USE OF THIS MACHINE .....	7
2.7. SERVICE .....	8
<b>3. WARNING SIGNS</b> .....	9
<b>4. ASSEMBLY INSTRUCTIONS</b> .....	10
4.1. ASSEMBLY .....	10
<b>5. OPERATING INSTRUCTIONS</b> .....	12
5.1. CONDITIONS OF USE .....	12
5.2. FUEL AND OIL .....	13
5.3. FILLING THE FUEL TANK .....	14
5.4. ENGINE OIL .....	15
5.5. STARTING THE MACHINE .....	16
<b>6. USING THE MACHINE</b> .....	19
6.1. CHIPPING BRANCHES .....	19
<b>7. MAINTENANCE AND SERVICE</b> .....	20
7.1. VISUAL INSPECTION .....	21
7.2. CLEANING .....	21
7.3. MAINTENANCE OF ENGINE .....	22
7.4. PERIODIC MAINTENANCE .....	26
<b>8. TROUBLE SHOOTING</b> .....	27
<b>9. TRANSPORTATION</b> .....	28
<b>10. STORAGE</b> .....	29
<b>11. RECYCLING AND MACHINE DISPOSAL</b> .....	30
<b>12. WARRANTY CONDITIONS</b> .....	30
12.1. WARRANTY PERIOD .....	30
12.2. EXCLUSIONS .....	30
<b>13. ILLUSTRATED PARTS LIST</b> .....	31

# 1. INTRODUCTION



Warning! Read all safety warnings and instructions. Failure to observe all warnings and instructions below can result in fire and/or serious injuries. Before using this machine, carefully read the information in this manual on the correct set up and safety techniques.

 The chipper is only designed to shred pieces of wood. It is prohibited to shred any other materials (for example metal, stones, plastics and any other materials). If you want to shred roots, remove the sand, mud or other residues before shredding. Any other use of the shredder not described here, voids the warranty responsibility of the manufacturer.

 Save all instructions for future references. If sold in the future, remember to give this manual to the new owner.

Remember that the machine operator is responsible for the damages and accidents caused to other people or things. The manufacturer and distributors will not be liable in any way for damages caused by improper or incorrect use of this machine.

# 2. SAFETY AND SECURITY MEASURES

 To avoid mishandling this machine please read all instructions in this

manual before using for the first time. All information included in this manual is important for your personal safety and that of other people, animals and things surrounding you. If you have any questions regarding the information contained in this manual ask a professional or visit the dealer where you purchased this machine to resolve it.

The following list of hazards and precautions include the likely situations that may occur during the use of this machine. If you encounter a situation not described in this manual use common sense to use the machine in the most secure way possible, or if you see danger, do not use the machine.

## **2.1. USERS**

This machine has been designed to be manipulated by users who have read and understood these instructions. This machine must not be used by children, or lack of experience or knowledge.

 Warning! Do not allow children to use this machine.

 Warning! Do not allow people who do not understand these instructions to use this machine. Before using this machine, familiarize yourself with it ensuring that you know perfectly where the controls and safety devices are, and the manner in which it must be used. If you are an inexperienced user we recommend you practice doing a simple job and if possible, in the company of an experienced person. The cutting tool of this machine is very sharp. It is

dangerous to use this machine improperly.

 Warning! Only lend this machine to persons who are familiar with this type of machine and know how to use it. Always lend the machine along with the user instruction manual so the new user can carefully read it and understand it. Place the machine on a flat surface and make sure it's stable before starting it. Create a work area with a width of 3 meters and a length of 10 meters in the direction where the residues are expelled. During the shredding process, the users must ensure that nobody is injured with the material expelled from the machine. Mark the working area with for example with red and white beacons. Always place the switch in the off position when:

- The machine is not being watched over.
- Maintenance work is being carried out.

Carry out periodic maintenance inspections (see “Maintenance and service” section).

## **2.2. PERSONAL PROTECTION**

Do not use this machine while tired or under the influence of alcohol, drugs or medication. A moment of inattention, serious injuries to people or damage to machine could occur.

Any tools or parts left on or in the machine, can cause serious damages to the machine, or injuries to the people around. Clear up the surroundings and

remove all tools around the machine.

Always use personal safety equipment, such as goggles, earmuffs and gloves.

The machine is working with noise over 90dB; ear muffs are a must while working with the machine. If ears are not protected, long time working noise could affect user's listening ability.

Do not wear loose clothing or ties during working.

Make sure the machine is well balanced and stand firmly on ground all the times.

## **2.3. ENVIRONMENT SECURITY**

Do not use this machine in an explosive place or nearby flammable liquid, gas or dust. The machine should only be used outdoor.

Do not use the machine at night, in a foggy day or any situation with less visibility. Clear up the working area, and work with good lighting.

When the machine is operated by two persons at the same time, make sure the position of another person is safe, before you start the machine.

## **2.4. SAFETY IN THE WORK AREA**



Do not operate this machine in explosive atmosphere as well as in the presence of flammable liquids, gases and dust.

Never start the machine in enclosed areas such as rooms or garages. This



machine emits gases through the exhaust pipe that will accumulate in the area causing the air to be toxic and harmful to the health of people, animals and plants that are inside the area. Do not start the machine in a room or enclosed space. The exhaust fumes and fuel fumes contain carbon monoxide and harmful chemicals.

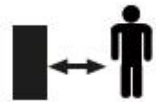

The area within a radius of 10 meters around the machine should be considered risk area in which no one must enter while the machine is running (security area). When necessary, use ropes and warning signs to mark the security area.

Maintain children and curious persons away from the work area while operating this machine. Distractions can cause a loss of control. Make sure the children, people or animals do not come into your work area.

When the work must be performed simultaneously by two or more persons, always check the presence and location of others in order to maintain a sufficient distance between each person to ensure safety.

## 2.5. SAFETY IN THE USE OF FUELS



**IMPORTANT:** The fuel used for this machine is highly flammable. If the fuel or the machine ignites, smother the fire with a dry powder fire extinguisher.

Petrol and oil are hazardous; avoid contact of gasoline or oil with the skin and



eyes. Do not inhale or swallow them. Immediately see your doctor if you ingest fuel or oil. If you accidentally come into contact with fuel or oil clean with soap and water as soon as possible, if you then continue to feel irritated or unwell immediately consult a doctor.



Do not refuel in enclosed or poorly ventilated areas or near flames.

Fumes from the fuel and oil contain hazardous chemicals. In the case of a concentration of gases produced by insufficient ventilation, remove all that impedes the flow of clean air from the area in order to improve the flow of clean air from the area in order to improve ventilation. Do not return to the area unless you have properly ventilated the area and are certain that ventilation is sufficient so this does not happen again.



Petrol and oil are extremely flammable and explosive under certain conditions. Do not smoke in the area. Keep flames, sparks or heat

sources away from the machine.

Do not smoke while transporting fuel, or when you are working with the machine.

Do not refuel in locations where there is the presence of open flames, sparks or heat sources. Fill the tank always in well-ventilated areas and with the motor stopped. Do not overflow fuel when filling the fuel tank. Make sure to correctly and tightly close the cap on the fuel after refilling. In the event of a fuel leakage, be sure to clean these leaks completely before starting, move the machine away from the spillage area and avoid any source of ignition until all vapours

are gone. Add fuel before starting the machine.

Never remove the cap of the fuel tank while the engine is running or when the machine is hot. Make sure the cap of the fuel is tightly and correctly closed while you are using the machine.

Do not use fuel that has been stored for longer than 2 months.

## **2.6. CARE AND USE OF THIS MACHINE**

 The chipper is only designed to shred pieces of woods. It is prohibited to shred any other materials (for example metal, stones, plastics and any other materials). If you want to shred roots, remove the sand, mud or other residues before shredding. Any other use of the shredder not described here, voids the warranty responsibility of the manufacturer.

Check that all the safety devices are installed and in good condition.

Remember that the machine operator is responsible for the dangers and accidents caused to other people or things. The manufacturer will not be in any way liable for damages caused by improper or incorrect use of this machine.

The cutting tool is very sharp. Not following the instructions may cause severe damages.

Keep this machine maintained and in proper conditions. Check that the moving parts are not misaligned or locked, that there are no broken parts or other conditions that may affect the operation of this machine. Whenever this

machine is damaged, repair it before use. Many accidents are caused by poorly maintained machines.

Check:

- The machine and look for loose and damaged parts (screws, nuts and etc).
- Engine oil level.
- Damaged and /or defective welded parts.

Make sure that the machine undergoes adequate maintenance controls. All damages caused by the use of defective, worn out or non original parts, annuls the warranty responsibility of the manufacturer.

Keep your face and body as far away from the machine as possible. Whilst introducing the wood into the machine for shredding, maintain both feet at the same level as those of the wheels.

Turn off the machine, disconnect the spark plug and make sure that the cutting tool has stopped before making any adjustments, filling with fuel, changing accessories, cleaning, transportation and storage of this machine. Such preventive safety measures reduce the risk of accidental starting of this machine.

Never tilt the machine when the engine is running.

Replace the caution signs if damaged or if not legible.

Reduce the engine speed when shutting down the engine, and if the engine has a petrol closing valve, then close this valve when the engine is not running.

## **2.7. SERVICE**

Please periodically check your machine by a qualified repair service agent using only original replacement parts. This will ensure that the safety of this machine is maintained.

### 3. WARNING SIGNS

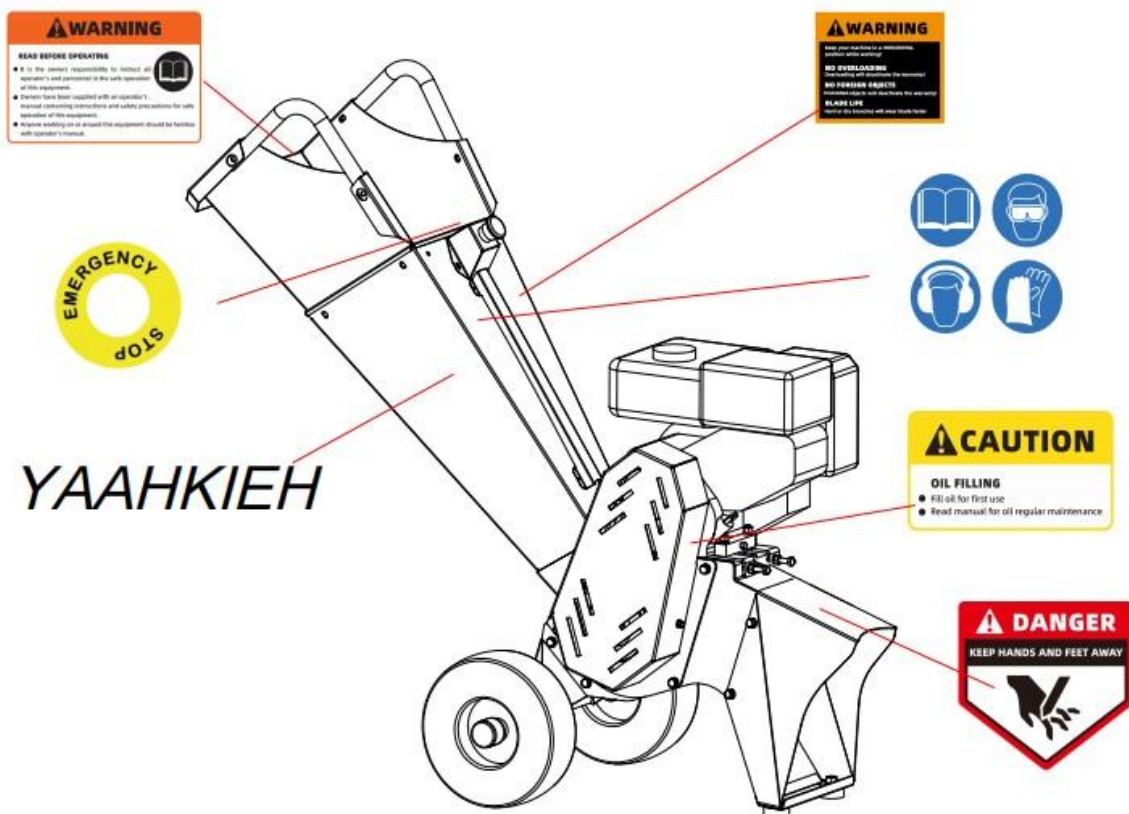

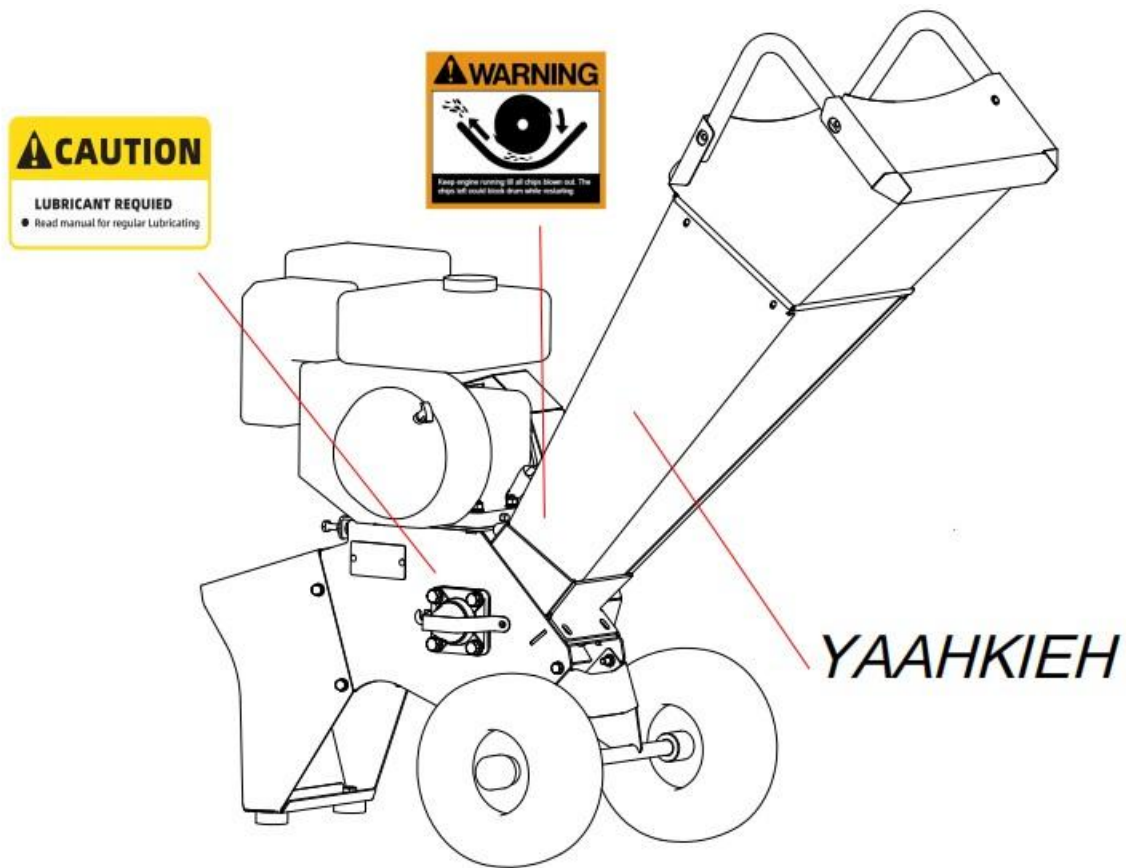

## 4. ASSEMBLY INSTRUCTIONS

### 4.1. ASSEMBLY

*In the process of installation, do not touch the blades with your hands or any other body parts.*

*All bolts, nuts and washers have been fixed on the machine in the factory, please remove them before assembly and put back on the machine at the same locations.*

Step 1. - Wheels and wheel axle.

Figure 1.

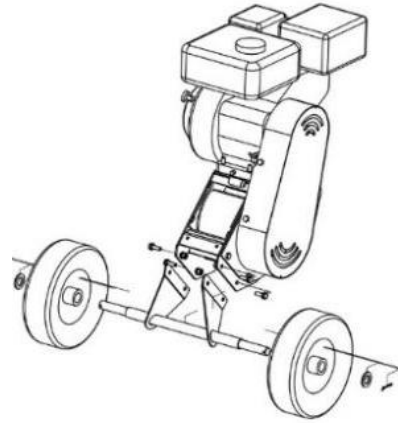

Step 2. - Support feet and discharge chute.

Figure 2.

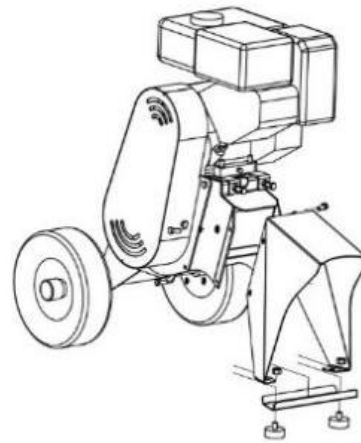

Step 3. - Feeding chute and hopper tray.

Figure 3.

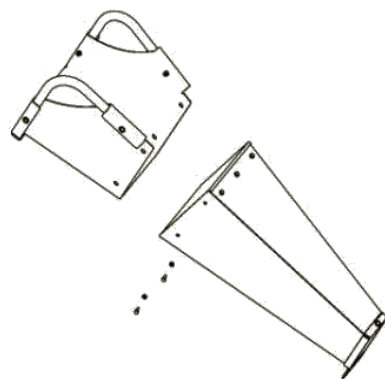

Step 4. - Chute assembly.

Figure 4.

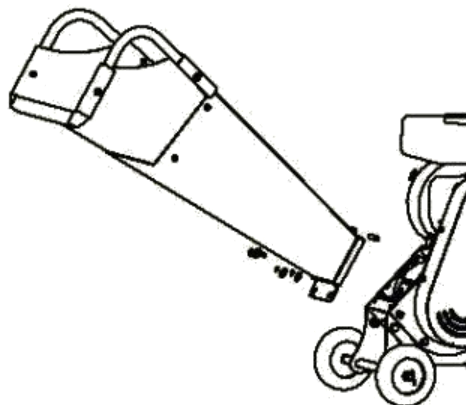

Step 5. – Connect the emergency cable. Fix the switch box by tightening the two bolts (A), and then connect the cable plug.

Figure 5.

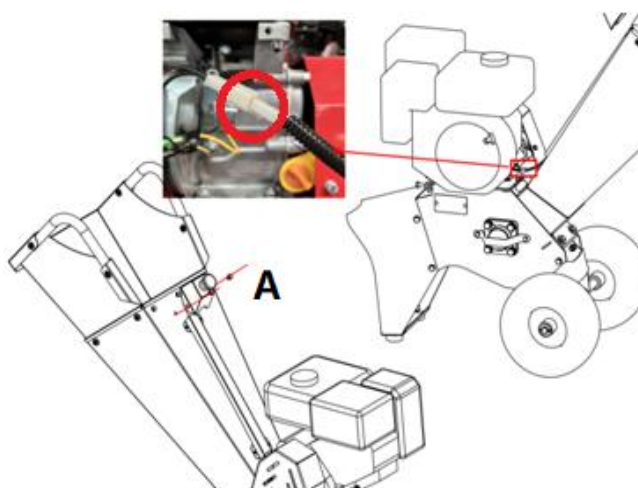

## 5. OPERATING INSTRUCTIONS

### 5.1 CONDITIONS OF USE

The chipper is only designed to shred pieces of wood. It is prohibited to shred

any other materials (for example metal, stones, plastics and any other materials). If you want to shred roots, remove the sand, mud or other residues before shredding. Any other use of the shredder not described here, annuls the warranty responsibility of the manufacturer. Do not use this machine for any other purpose not intended. The use of this machine for other than the designated operations may result in dangerous situations. Use this machine outdoors, in dry environments and temperatures between 5°C to 45°C.

Remember that the machine operator is responsible for the dangers and accidents caused to other people or things. The manufacturer and distributors shall not be in any case responsible for damages caused by improper or incorrect use of this machine.

## **5.2 FUEL AND OIL**

**IMPORTANT:** The fuel used for this machine is highly flammable. If the fuel or the machine ignites, put out the fire with a dry power extinguisher.

Petrol and oil are extremely flammable and explosive under certain conditions. Do not smoke near the machine. Keep flames, sparks or heat source away from the machine.

Use unleaded petrol only.

Do not use fuel that has been stored for longer than 2 months. A fuel stored for too long will cause the starting of the machine to be more difficult and result in



unsatisfactory engine performance. If the fuel has been in the machine's tank for longer than two months, empty the tank and replace it with fresh fuel.

### **5.3. FILLING THE FUEL TANK**

1. Choose a suitable area to perform this operation.
2. Remove the fuel tank cap and fill with fuel.
3. Tightly close the fuel tank cap and remove all any spilled fuel with a dry cloth.

**WARNING:** Stop the engine before refuelling.

Do not start the machine in an enclosed room or space. The exhaust gases and fumes from the fuel and oil contain carbon monoxide and harmful chemicals.

In case of a large amount of gases produced by poor ventilation, stop the engine safely. Do not return to the working area unless you have properly ventilated the area and are certain that ventilation is sufficient so that this does not happen again.

Do not refuel in locations where there is the presence of open flames, sparks or heat sources. Always fill the tank in well-ventilated areas and with the motor stopped. Don't overfill the fuel tank. In the event of a fuel leakage be sure to remove these leaks completely before starting, move the machine away from the area of spillage and avoid any source of ignition until all vapours are gone. Keep yourself at least 3 meters from the refuelling area before starting the machine.

Add fuel before starting the machine. Never remove the fuel tank cap while the engine is running or when the machine is hot.

Do not use fuels such as ethanol or methanol. These fuels will damage the engine of the machine.

## 5.4. ENGINE OIL

For transportation reasons, your machine's engine comes from the factory without any oil in it. Before starting the engine for the first time you must put oil the engine.

This engine uses quality 4-stroke Briggs and Stratton SAE30 or Honda 10W30 oil, depending on the model.

Filling the oil sump:

- Place the machine on a flat, horizontal and uncluttered surface.
- Unscrew the oil filler cap (Figure 6).

Figure 6.

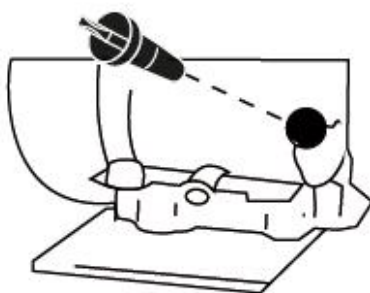

- Add 0.6L of oil.
- Wait 1 minute for the oil to completely go down to the crankcase.
- Clean the dipstick from the oil with a cloth.
- Insert the rod and screw on the oil cap.

- Unscrew the plug again and check the mark left by oil on the dipstick. The mark left by the oil must be between the minimum and maximum marks (Figure 7).
- If the mark is below the minimum, add a little bit more oil and recheck.
- If the mark is above the maximum, you will have to remove oil from the crankcase. To do this, tilt the machine and let out a small amount of oil (put a container at the end of the tube to prevent oil spilling on the machine or the ground).

Figure 7.

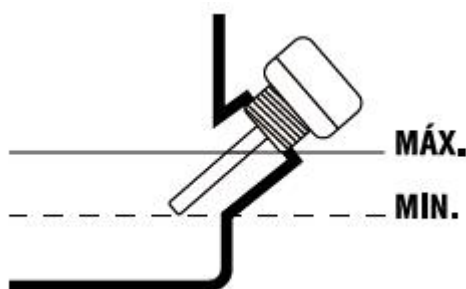

## **5.5. STARTING THE MACHINE**

### **5.5.1. CHECKPOINTS BEFORE STARTING**

The machine must be operated as instructed below:

Keep hands, other extremities and clothes clear of the feeding chute, clear of the discharge chute and clear of all rotating elements.

Maintain a good balance on both feet. Do not lean on the machine.

Maintain yourself well clear of the discharge area whilst the machine is working.

If the machine gets stuck, you must stop it and wait for the blades to stop turning.

The use of working gloves, ear protections and protective glasses is mandatory.

The machine is designed for outdoor use only. Avoid using the machine in outdoor areas with a high probability of exhaust fumes.

Never insert your hands into the feeding chute until the machine has been stopped and the blades have stopped rotating.

The pieces of wood that might have got stuck transversally must only be removed when the machine has been stopped completely and the blades have stopped rotating.

Transportation of the machine should be carried out by two persons to avoid possible injuries.

### **5.5.2. STARTING THE ENGINE**

Before starting the engine make sure to check the engine oil and fuel tank.

To start the machine:

1. Turn the switch to 'ON' position (Figure 8).
2. Turn the choke lever to  position and open the fuel valve.
3. Pull the starting cord until the engine starts. Push the choke lever off.
4. Turn the throttle lever to fastest position. (must use highest speed while

chipping prevent machine from clogging)

- ❖ If engine is hot, it is not necessary to use the choke when restarting.

Figure 8.

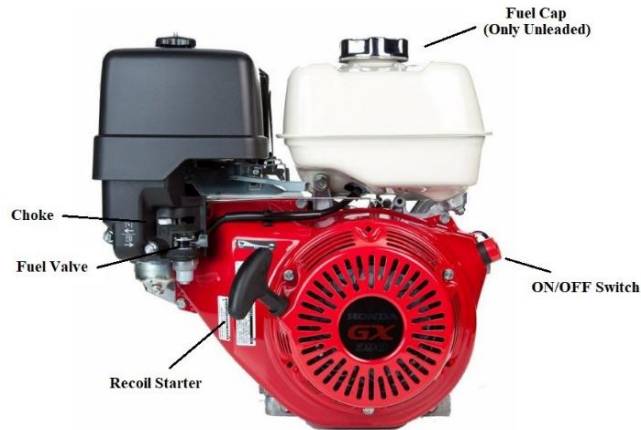

**\*NOTE\***

This machine is only used for the purpose that has been designed. To use it for other purpose may cause injure to people or damage to machine.

Put the branches into the chute and when they are pulled in, let them go. The branches will be pulled in automatically.

**\*Tips \***

*The hardness of the wood varies, of different wood type, the time between pruning and chipping and how dry the branches are. This machine performs best if the branches are chipped fresh right after pruned.*

**\*CAUTION\***

**Dry wood will wear blade faster than normal, even damaging the blades.**

### **5.5.3. STOPPING THE ENGINE**

1. Change the engine to idle status by turning the throttle to 'TURTLE' position for a minute.
2. To stop the engine, turn the engine 'ON/OFF' switch to the 'OFF' position.
3. When the engine has stopped completely, turn the fuel lever to the 'OFF' position as well.
4. Only use the emergency stop switch if there is a need to do so. Push the button and the chipper will stop.

#### **\*Tips \***

*Keep the machine running for another 3-5 seconds after feeding the last branch, and then turn the throttle lever to the lowest position before stopping the engine.*

*If the machine gets jammed, stop the machine, disassemble the bearing cover, and turn the rotor a few degrees by spanner till the rotor can turn freely. Check machine after work, to ensure all bolts, nuts and screws are tight. If loose, tighten them.*

## **6. USING THE MACHINE**

### **6.1. CHIPPING BRANCHES**

1. Stand to the side of the hopper, ensuring you have a stable stand and firm

footing.

2. When placing long branches into the feeding chute, remove twigs and smaller branches so that you are feeding a thin, straight piece into the machine.

3. Place branches 'thick-end-first'. Allow the machine's blades to take the branch from you. You will feel the blades pull the branch from you.

4. When finished chipping, turn 'OFF' the machine, allow all moving parts to come to a complete stop. Disconnect the spark plug wire before moving the machine, emptying the bag, unclogging the inlets or outlets, filling the fuel tank, or performing maintenance and repairs.

### **Chipping Tips:**

- DO NOT feed materials in excess of the diameter indicated. Large branches will cause the motor to stall.
- Chipping wood when it is green is easier on the machine. The blades will stay sharper for longer.
- The chipper/shredder will work best if the blades are sharp. Rotate, sharpen, or replace the blades as soon as chipper/shredder performance begins to deteriorate.

## **7.MAINTENANCE AND SERVICE**

**WARNING:** Turn OFF the machine, allow all moving parts to come to a

complete stop, and disconnect the spark plug wire before moving the machine, emptying the bag, unclogging the inlets or outlets, filling the gas tank, or performing any maintenance and repairs.

## **7.1. VISUAL INSPECTION**

Before and after every use of the wood chipper, it is recommended that the following inspection process takes place. This is quick and easy, and ensures your safety as well as the machine's performance.

1. Check the chutes and guards for cracks, holes and loose bolts.
2. Check the frame and base of the machine for cracks or damages.
3. Check all the bolts and screws to ensure tightness.
4. Wear gloves, and check the blades are not cracked or loose.
5. Check the engine oil level using a dipstick.

## **7.2. CLEANING**

It is strongly recommended to clean the machine after every use. After finishing the job, turn off the machine, allow the engine to cool fully, and remove the spark plug.

Brush off or vacuum excess wood chippings and wipe off the remaining dust from the exterior of the machine with a dry cloth. Do not expose the machine to water or attempt to clean by pouring water on/into it. Remove any chips or



debris from the hopper and the discharge chute.

It is increasingly difficult to clean this machine the longer you let it sit unclean. The machine's performance will naturally decrease if it is not properly cared after.

To clean the engine from built-up resins, you may need to purchase an engine cleaner.

## **7.3. MAINTENANCE OF ENGINE**

### **7.3.1 SPARK PLUG**

After every 100 hours of running the spark plug should be replaced. Check the colour of the deposits on the end of the spark plug. It should be a brown colour. Remove all deposits using a stiff brass wire. Check the spark plug gap (Figure 9) and adjust if required. The correct gap should be between 0.7 to 0.8mm.

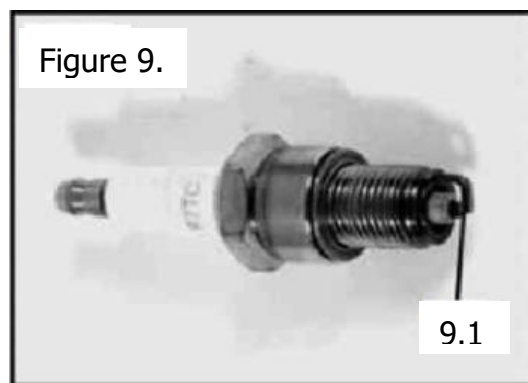

### **7.3.2 ENGINE OIL REPLACEMENT**

The oil should be replaced after approximately 50 hours of use. It is recommended you maintain an estimate of this by tracking your usage of the

machine.

1. As per normal start-up, ensure the machine is on a flat, dry surface and follow the previous instructions to startup the machine. Allow the engine to warm for several minutes before turning off the engine.
2. Remove the oil filler cap as seen in Figure 10.

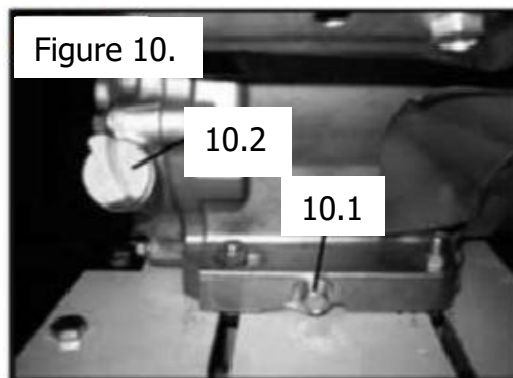

3. Place an oil pan under the engine to catch the oil. Remove the oil drain plug (as displayed in Figure 11) to drain the oil fully. A tube or similar device is recommended to avoid spilling the oil.
4. Check the oil drain plug, gasket, and oil filler cap to ensure each part is not damaged.
5. Add fresh engine oil up to the upper level of the dipstick, as seen in Figure

11.

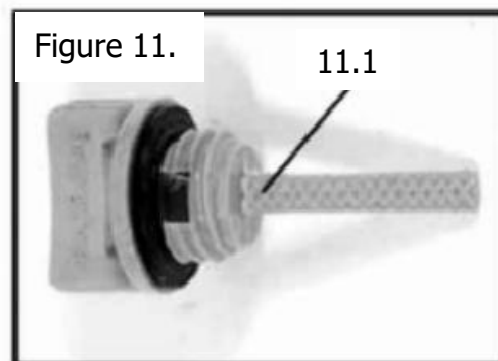

### **7.3.3 AIR FILTER**

After approximately 100 hours of use, or every month (whichever is sooner), the air filter should be removed and cleaned thoroughly. During this cleaning process, the air filter should also be thoroughly inspected for damages and deterioration. We recommend a water-based degreasing agent. Allow to dry fully before replacing the air filter.

**NOTE:** Never attempt to run the machine without an air filter in place.

### **7.3.4 BLADES AND ANVIL**

#### **\*CAUTION\***

**Blades are extremely sharp, take care please!**

**Torque scale: 60-70Nm for blade and 35-45Nm for anvil.**

Blades and anvil need cleaning after every chipping job, to protect it from corrosion.

Sharpen or replace the blades as soon as the chipping performance begins to deteriorate, or if you notice signs of chips or cracks.

1. Stop the engine (Put the ON/OFF switch in the "OFF" position) and disconnect the safety switch cable.
2. Remove the feeding chute.
3. Put a rod into the hole (Figure 12). Pull the starter cord some more until the rotor is blocked. Now it is safe to unscrew blade bolts. Always use gloves when handling the blades.

Figure 12.



4. Remove the blade anvil. Give a really good clean of chipper blades and anvil and make sure there is no dirt.
5. Put the anvil back to the chipper and screw on (make sure to keep anvil bolts loose as you need to adjust it later).
6. Use threadlocker on blade bolts (make sure you don't use too much, normally just a small dip) and screw on the blades (make sure all bolts are tightened).
7. After installing the blades, check the gap between the blades and the anvil. The gap should be no smaller than 0.5mm and not bigger than 1mm. Make sure the anvil is tightened.

### **Sharpening:**

Blades must only be sharpened by grinding on a bench grinder. Do not sharpen with hand held equipment. Always sharpen in sets to maintain balance of rotor

assembly. Both edges of each blade must be grounded on front at 30° angle and on the back 5° angle over 2mm to ensure correct clearances (Figure 13).

Figure 13.

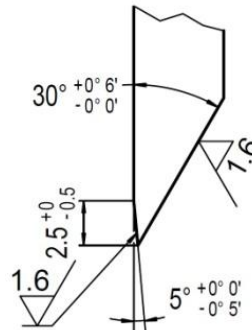

### **Anvil:**

For the anvil, change side when the side edge on the tapered top gets blunt. Change the anvil when both sides are blunt to ensure performance of the chipper. Remember to readjust the anvil to a clearance of 0.5~1mm.

## **7.3.5 LUBRICATING GREASE**

It is recommended to grease the rotor bearings daily before use. Use a high temperature EP2 lithium complex grease.

## **7.3.6 WHEEL TYRE**

Check the tyres regularly. Inflate the tube if necessary.(tyre pressure 1.5 bar min., 1.9 bar max.)

## **7.4 PERIODIC MAINTENANCE**

Perform regular inspections of the machine in order to ensure effective operation of the machine and to prevent risk of injury to machine and user.

Replacement parts should be purchased from the official service dealers.

The use of non-official spare parts may cause accident, injury to the user and scrapping of the machine.

Perform maintenance frequently as indicated in the following table:

Maintenance	Every use	First 10 hours	Every 50 hours	Every 100 hours	First use of season	Last use of season
Grease parts	x					
Check oil level	x					
Change oil		x	x	x	x	
Empty oil and fuel						x
Clean air filter	x					x
Check spark plug			x		x	
Belt checking	x					
Blade checking	x					

## 8. TROUBLE SHOOTING

If the machine does not start, check the compression of the engine and the spark from the spark plug. Depending on the symptoms that you notice, you can discover the probable cause and solve the problem.

Symptom	Possible Cause	Possible Solution
Engine will not start.	Control levers are not in correct positions for starting	Make sure the ON/OFF switch is ON, the fuel shut-off valve is open, and the choke and throttle controls are in the start position
	Spark plug wire is not connected to the spark plug, or the spark plug is bad	Connect the spark plug wire or replace the spark plug
	No fuel, or fuel is old and stale	If empty, fill the tank. If full, drain the fuel, then fill the tank with fresh petrol
	Air filter is dirty	Clean/replace the air filter
	Engine oil is low	Add oil to the engine

	Emergency stop button switched on	Switch off emergency stop button
	Blocked fuel line	Clean out the fuel line
Engine does not run smoothly	Engine is warm, and the choke is still in the CHOKE position	Move the choke to the RUN position
	Air filter is dirty	Clean/replace the air filter
	Stale fuel, water or dirt in fuel, blocked fuel line	Drain the fuel tank, clean out the fuel line, and fill the tank with fresh petrol
Engine overheats	Chips and sawdust around the motor	Clean off the motor
	Dirty air filter	Clean/replace the air filter
Machine vibrates or makes unusual noises	Loose or damaged parts	Check the blades, hammers, impeller, and all connections. Tighten, repair, or replace any loose or damaged parts
	Impeller or blades have woody residues or chunks stuck to them	Clean the impeller and blades
Chipper no longer chips well	Dull or damaged blades and anvil	Sharpen or replace blades and check the anvil for damage.
Chips do not come out of the discharge chute or come out slowly	Discharge chute or hopper is clogged	Turn OFF the motor, disconnect the spark plug, then clean out the machine
	Insufficient motor RPM	Move the throttle to FAST
Rotor cannot pull branches	Oversize input	Take input out and make it right
Chips are not in similar size	Gap between blade and anvil is not right	Right adjustment is needed on anvil. The gap should be no smaller than 0.5mm and not bigger than 1mm.
Rotor gets jammed	Material being chipped is not right	Only chip materials as indicated
	Too much input	Adjust input
Conveyor gets jammed	Too much wet, soft or light materials	Disassemble the conveyor and remove the jammed materials

## 9. TRANSPORTATION

Never lift or transport the chipper while the engine is running. It is necessary to always turn off the engine when transporting the machine between different

working areas.

Once the machine is turned off, wait for 5 minutes to allow it to cool before transporting it. The machine's exhaust pipe will remain hot after turning off the engine.

If you have to raise the machine, check the weight of the machine in the technical characteristics before lifting it to ensure that it is a weight that you can withstand.

Transportation of the machine should be carried out by two persons to avoid possible injuries.

## **10. STORAGE**

Once the machine is switched off, wait for 5 minutes for it to cool down before storing the machine. The machine's exhaust pipe will remain hot after turning the engine off. Never store the machine in places near flammable materials (dried grass or wood), gas or fuels.

Be sure to store the machine in a place not accessible to children or that it may create possible danger for anyone and that is stored in a dry, clean place with a temperature between 0°C to 45°C.

If you plan to store the machine in a closed place, first empty the fuel. Vapours could come into contact with a flame or hot body and ignite. If the fuel tank has to be emptied, this must be done outdoors and according to the regulations of recycling.



To reduce the risk of fire, keep the engine, muffler and fuel tank clean by eliminating the remains of cut material, oil and grease.

## **11. RECYCLING AND MACHINE DISPOSAL**

Protect the environment. Recycle this machine's used oil by taking it to a recycling center. Do not pour used oil in drains, land, rivers, lakes, or seas.



Dispose of your appliance sustainably. We should not get rid of machines with domestic waste. Plastic and metal components can be classified according to their nature and recycled.

## **12. WARRANTY CONDITIONS**

### **12.1. WARRANTY PERIOD**

The warranty period for the chipper/shredder is 2 year (domestic use) and 1 year (commercial use) from the purchase date. Engine warranty is 3 years.

### **12.2. EXCLUSIONS**

Warranty will not cover:

- Pieces worn out due to normal wear and tear.
- Misuse, negligence of care, and lack of maintenance.
- Failures due to using non genuine replacement parts

Warranty will be voided if the machine has been modified in any way.

# 13. ILLUSTRATED PARTS LIST

## Section A.

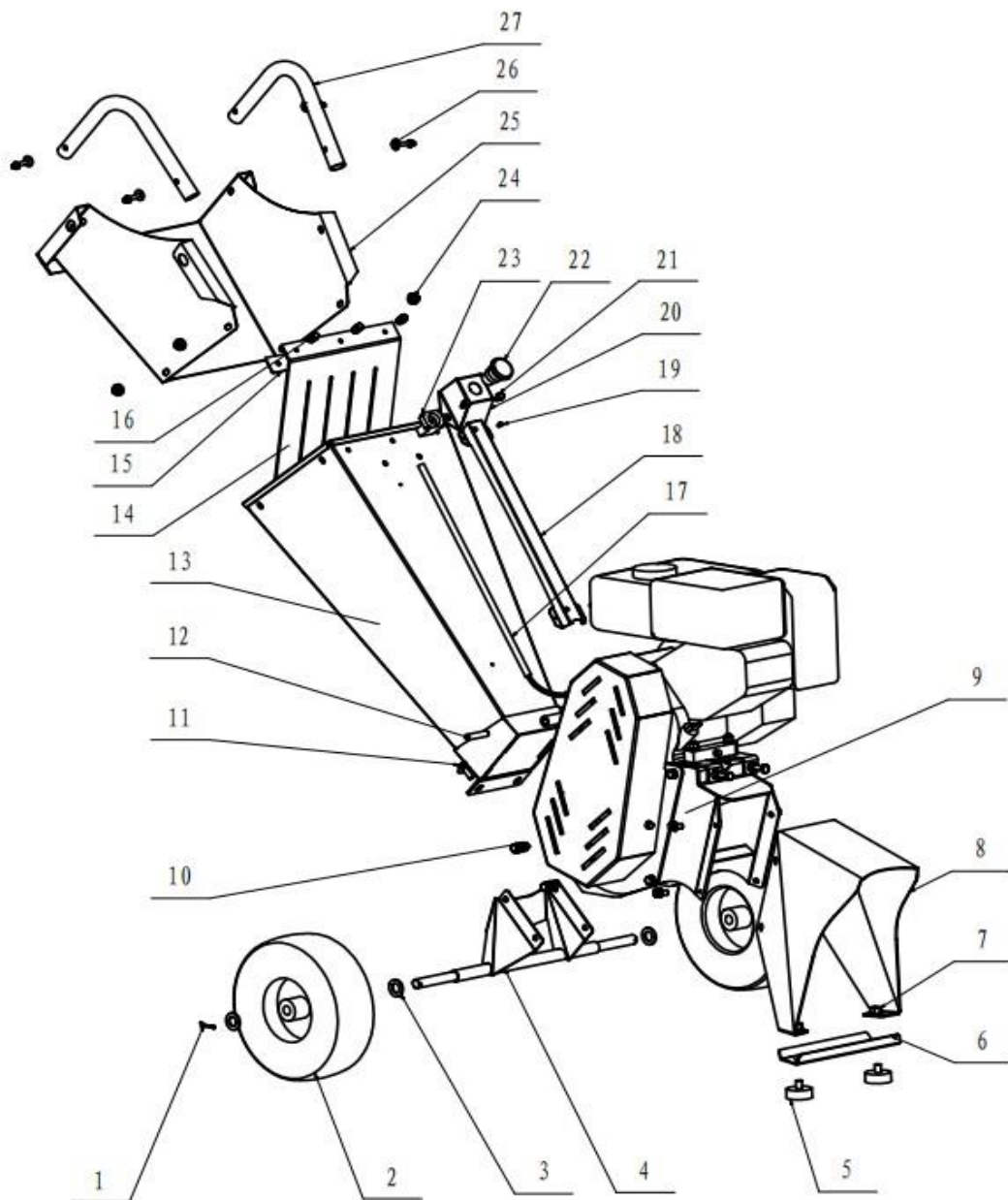

Ref No.	Part No.	Description	Quantity
1	R08PL00001	Split Pin 2.5×30	2
2	R08PL00002	Wheel	2

3	R08PL00003	Washer $\Phi$ 16	4
4	R08PL00004	Wheel Axle Assembly	1
5	R08PL00005	Rubber Bumper	2
6	R08PL00006	Connector Plate	1
7	R08PL00007	Nut M10	2
8	R08PL00008	Discharging Chute	1
9	R08PL00009	Chip system Assembly	1
10	R08PL00010	Bolt M8x25	4
	R08PL00010-1	Nut M8	4
	R08PL00010-2	Spring Washer $\Phi$ 8	4
	R08PL00010-3	Washer $\Phi$ 8	4
11	R08PL00010	Bolt M8x25	2
	R08PL00010-2	Spring Washer $\Phi$ 8	2
	R08PL00011	Large Washer	2
12	R08PL00012	Chute Hitch Pin	1
13	R08PL00013	Feeding Chute	1
14	R08PL00014	Rubber Flap	1
15	R08PL00015	Flap Washer	1
16	R08PL00016	Nylon Locknut M6x16	3
	R08PL00016-1	Bolt M6x16	3
	R08PL00016-2	Washer $\Phi$ 6	3
17	R08PL00017	Emergency Cable	1
18	R08PL00018	Cable Cover	1
19	R08PL00019	Rivet 3x7	4
20	R08PL00020	Emergency Stop Station	1
21	R08PL00021	Bolt M6x12	2
	R08PL00021-1	Spring Washer $\Phi$ 6	2
	R08PL00016-2	Washer $\Phi$ 6	2
22	R08PL00022	Emergency Stop Button	1
23	R08PL00023	Emergency Stop Switch	1
24	R08PL00024	Inner Hex Head Bolt M6x16	4
	R08PL00016	Nylon Locknut M6x16	4
	R08PL00021-1	Spring Washer $\Phi$ 6	4
25	R08PL00025	Hopper Tray	1
26	R08PL00026	Inner Hex Head Bolt M6x40	4
	R08PL00026-1	Nylon Locknut M6x40	4
	R08PL00021-1	Spring Washer $\Phi$ 6	4
27	R08PL00027	Handle	2

## Section B.

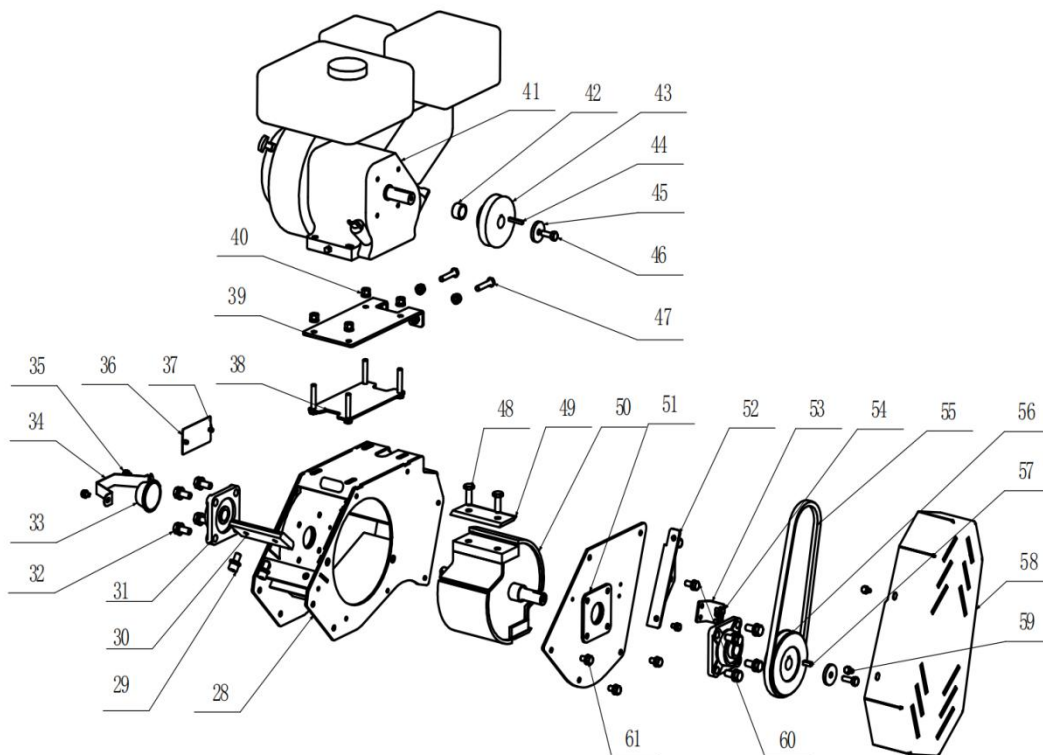

Ref No.	Part No.	Description	Quantity
28	R08PL00028	Rotor Housing (only)	1
29	R08PL00029	Inner Hex Head Bolt M10×20	2
	R08PL00029-1	Spring Washer Φ10	2
	R08PL00029-2	Washer Φ10	2
30	R08PL00030	Anvil	1
31	R08PL00031	Bearing UCF204	2
32	R08PL00032	Bolt M10×25	8
	R08PL00029-1	Spring Washer Φ10	8
	R08PL00029-2	Washer Φ10	8
33	R08PL00033	Bearing Cap	1
34	R08PL00034	Bearing Cap Holder	1
35	R08PL00035	Bolt M6×10	2
	R08PL00021-1	Spring Washer Φ6	2
	R08PL00016-2	Washer Φ6	2
36	R08PL00036	Serial Number Plate	1
37	R08PL00037	Rivet 4×14	2
38	R08PL00038	Tension Plate Holder	1

39	R08PL00039	Tension Plate	1
40	R08PL00040	Hex Nut M8	4
	R08PL00010-2	Spring Washer $\Phi$ 8	4
	R08PL00010-3	Washer $\Phi$ 8	4
41	R08PL00041	Engine, Briggs & Stratton 6.5HP	1
	R08PL00041-1	Engine, Honda GX200	1
42	R08PL00042	Engine Shaft Bush	1
43	R08PL00043	Engine Pulley	1
44	R08PL00044	Engine Key	1
45	R08PL00045	Pulley Lock Washer	2
46	R08PL00046	Bolt M8 $\times$ 25	2
	R08PL00010-2	Spring Washer $\Phi$ 8	2
	R08PL00010-3	Washer $\Phi$ 8	2
47	R08PL00047	Bolt M8 $\times$ 40	2
	R08PL00047-1	Nut M8 $\times$ 40	2
	R08PL00010-2	Spring Washer $\Phi$ 8	2
48	R08PL00048	Blade Bolt	4
49	R08PL00049	Blade	2
50	R08PL00050	Blade Rotor	1
51	R08PL00051	Rotor Housing Side Cover	1
52	R08PL00052	Belt Cover Holder	1
53	R08PL00053	Belt Cover Holder 2	1
54	R08PL00054	Bolt M6 $\times$ 12	3
	R08PL00021-1	Spring Washer $\Phi$ 6	3
	R08PL00016-2	Washer $\Phi$ 6	3
55	R08PL00055	V-Belt	1
56	R08PL00056	Pulley Rotor	1
57	R08PL00057	Key Rotor 6 $\times$ 6 $\times$ 16	1
58	R08PL00058	Belt Cover	1
59	R08PL00016-1	Bolt M6 $\times$ 16	3
	R08PL00021-1	Spring Washer $\Phi$ 6	3
	R08PL00016-2	Washer $\Phi$ 6	3
60	R08PL00060	Bolt M8 $\times$ 20	1
	R08PL00010-2	Spring Washer $\Phi$ 8	1
	R08PL00010-3	Washer $\Phi$ 8	1
61	R08PL00061	Bolt M8 $\times$ 16	4
	R08PL00010-2	Spring Washer $\Phi$ 8	4
	R08PL00010-3	Washer $\Phi$ 8	4

## Section C.



Ref No.	Part No.	Description	Quantity
62	R08PL00062	Catcher	1



## **Customer Service:**

Website: [www.YAAHKIEH.com](http://www.YAAHKIEH.com)

Email: [INFO@JONCOLTD.com](mailto:INFO@JONCOLTD.com)

Spare parts are available from our dealers and our official website

Search **\*JONCO CHIPPER\*** on FACEBOOK, or **\*YAAHKIEH\*** on INSTAGRAM